

Service Schematics

NOKIA 6125

Introduction

IMPORTANT:

This document is intended for use by authorized NOKIA service centers only.

“Service Schematics” was created with focus on customer care. The purpose of this document is to provide further technical repair information for NOKIA mobile phones on Level 3/4 service activities. It contains additional information such as e.g. “Component finder”, “Frequency band table” or “Antenna switch table”. The “Signal overview” page gives a good and fast overview about the most important signals and voltages on board. Saving process time and improving the repair quality is the aim of this document. It is to be used additionally to the service manual and other training or service information such as Service Bulletins.

All measurements were made using following equipment:

Nokia repair SW	: Phoenix version 2005.44.4.120
Oscilloscope	: Fluke PM 3380A/B
Spectrum Analyzer	: Advantest R3162 with an analog probe
RF-Generator / GSM Tester	: Rhode & Schwarz CMU 200
Multimeter	: Fluke 73 Series II



While every endeavour has been made to ensure the accuracy of this document, some errors may exist. If the reader finds any errors, NOKIA shall be notified in writing.

Please send E-Mail to: training.sace@nokia.com

Copyright © NOKIA

This material, including documentation and any related computer programs is protected by copyright, controlled by NOKIA. All rights are reserved. Copying, including reproducing, modifying, storing, adapting or translating any or all of this material requires the prior written consent of NOKIA. This material also contains confidential information, which may not be disclosed to others without the prior written consent of NOKIA.

Table of Contents	Page
Front page	1
System connector	2
RETU	3
TAHVO	4
RAPGSM, Combo memory, Micro SD	5
User Interface	6
Camera, Earpiece, IHF speaker	7
Bluetooth, FM radio	8
RF part	9
Signal overview	10
Component finder	11
Component finder UI	12

Exploded view and component disposal

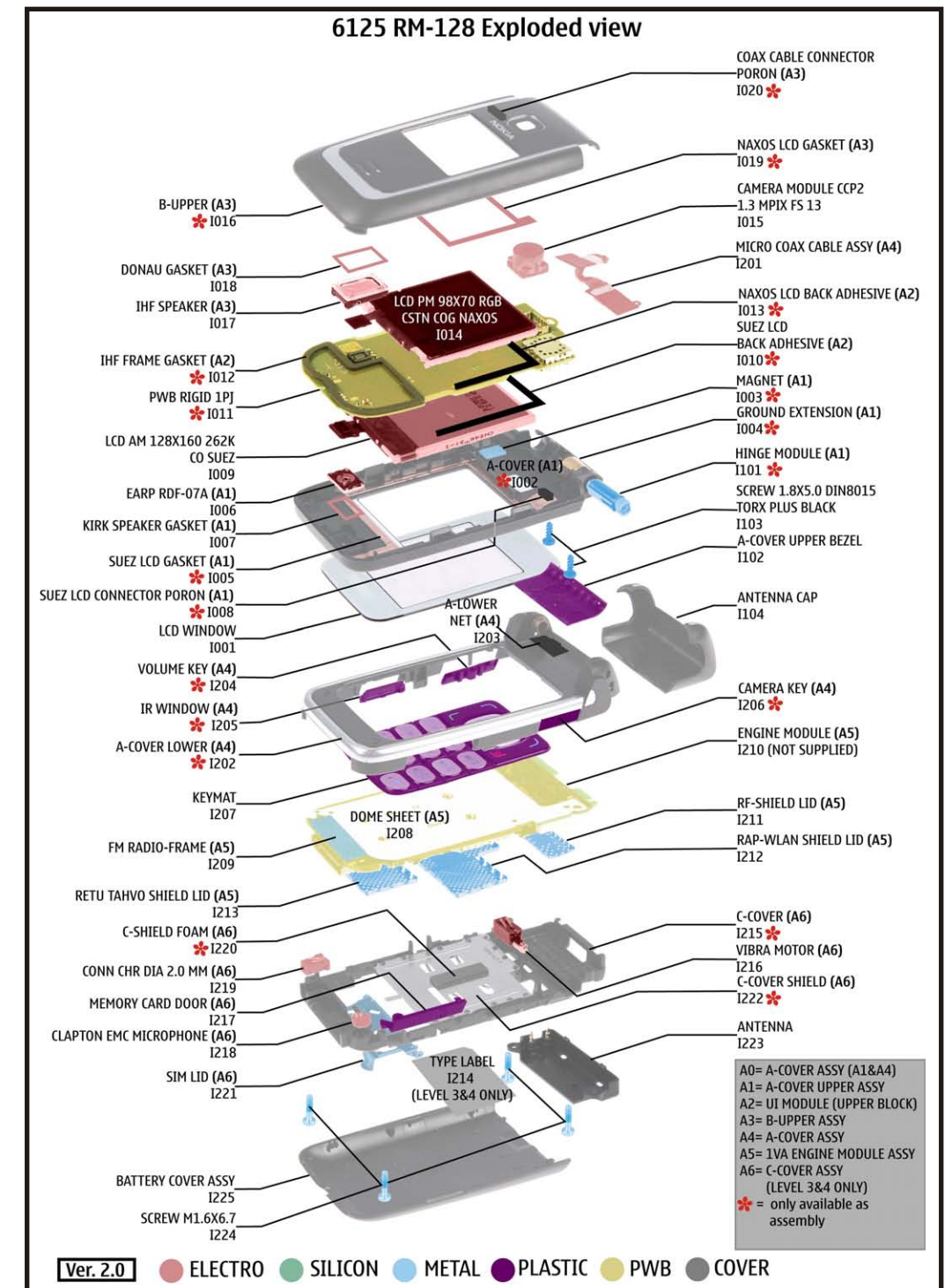

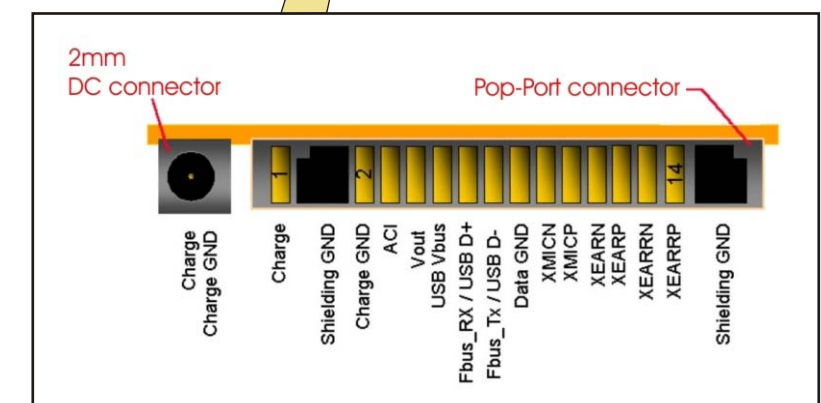
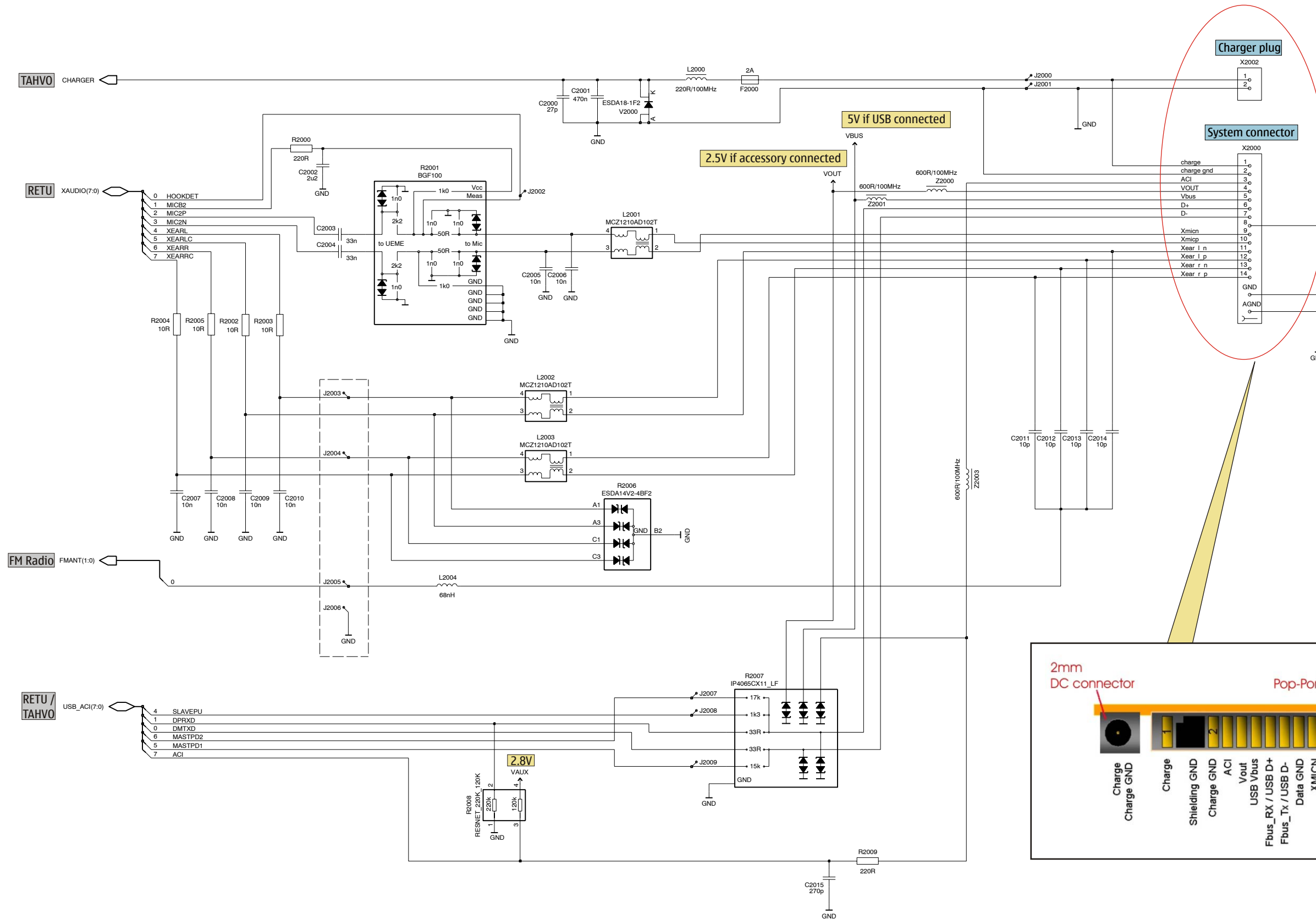

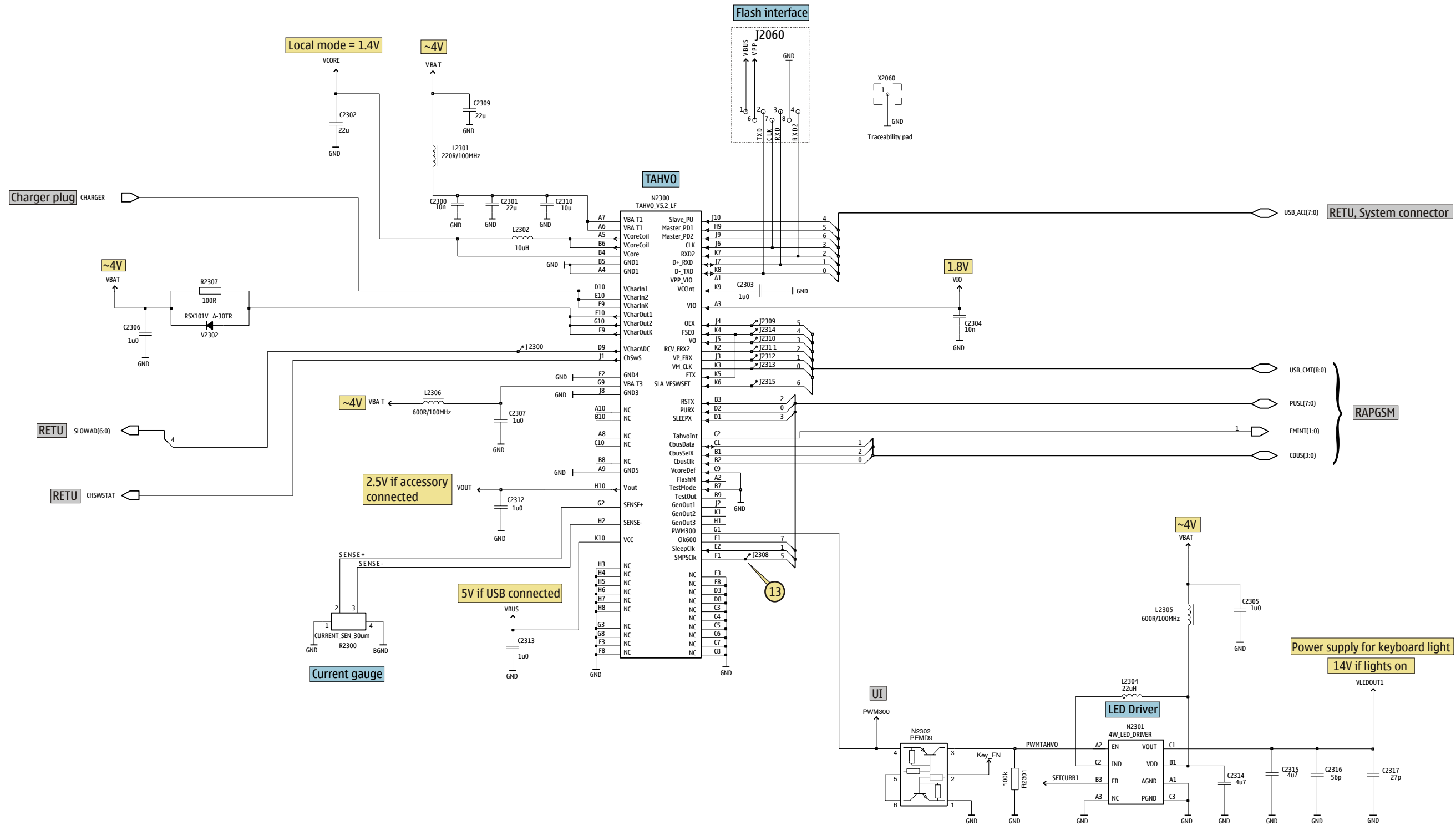

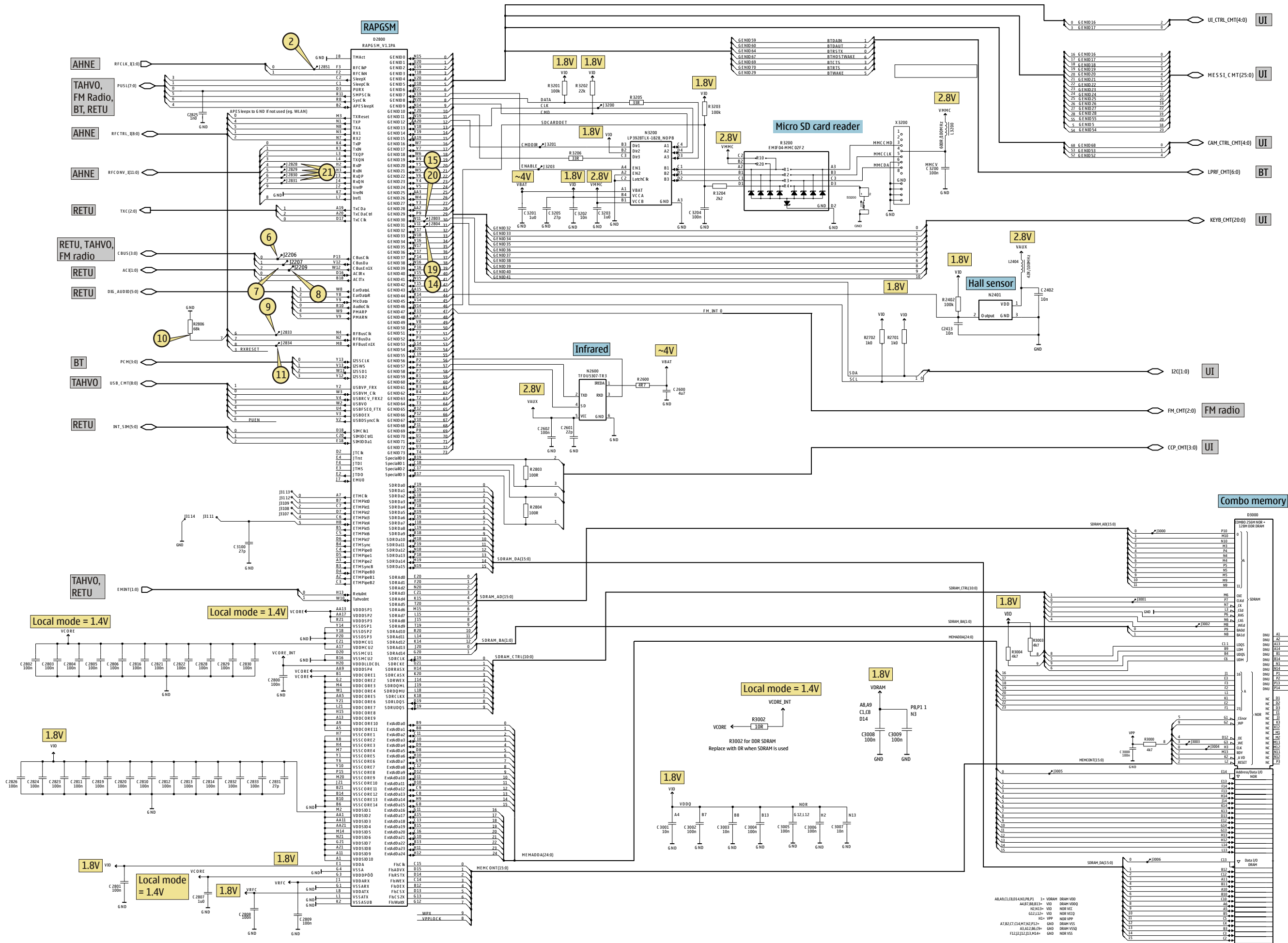

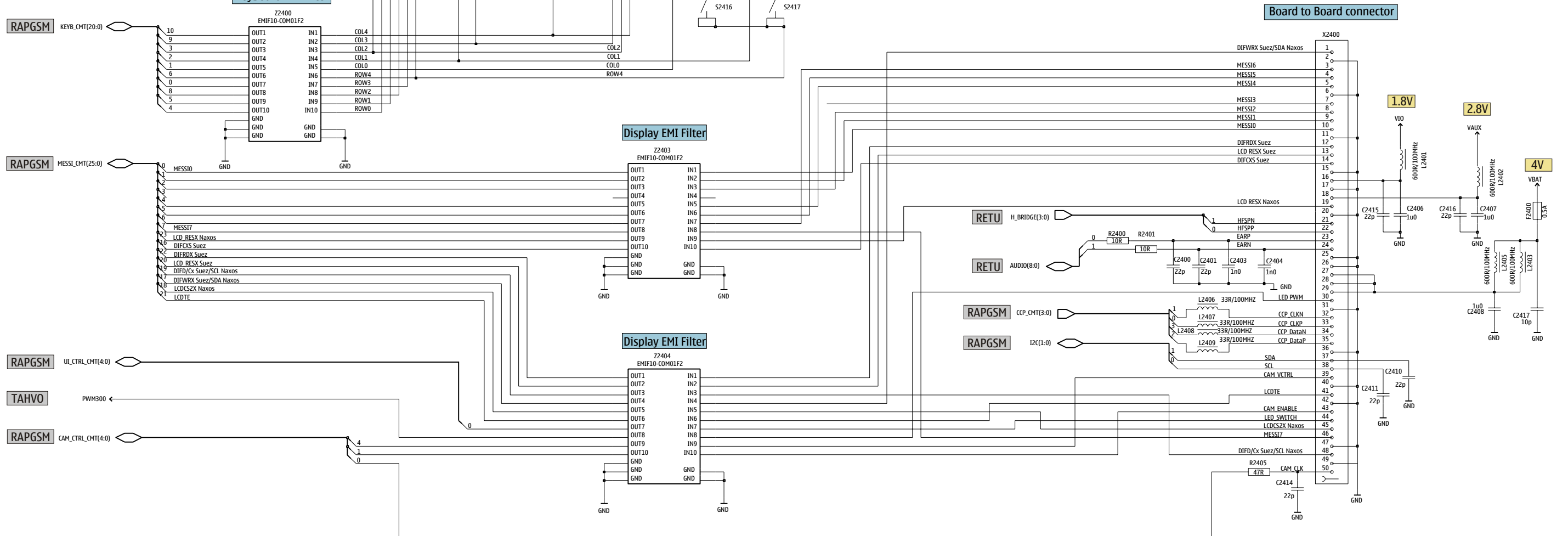
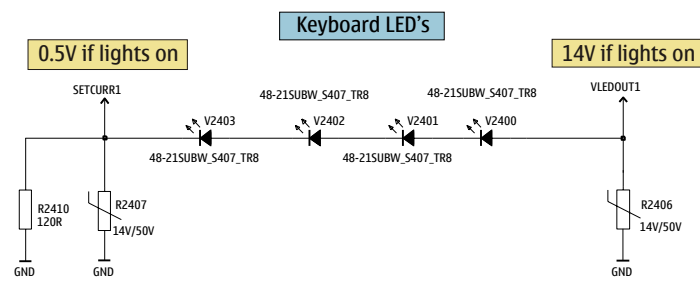
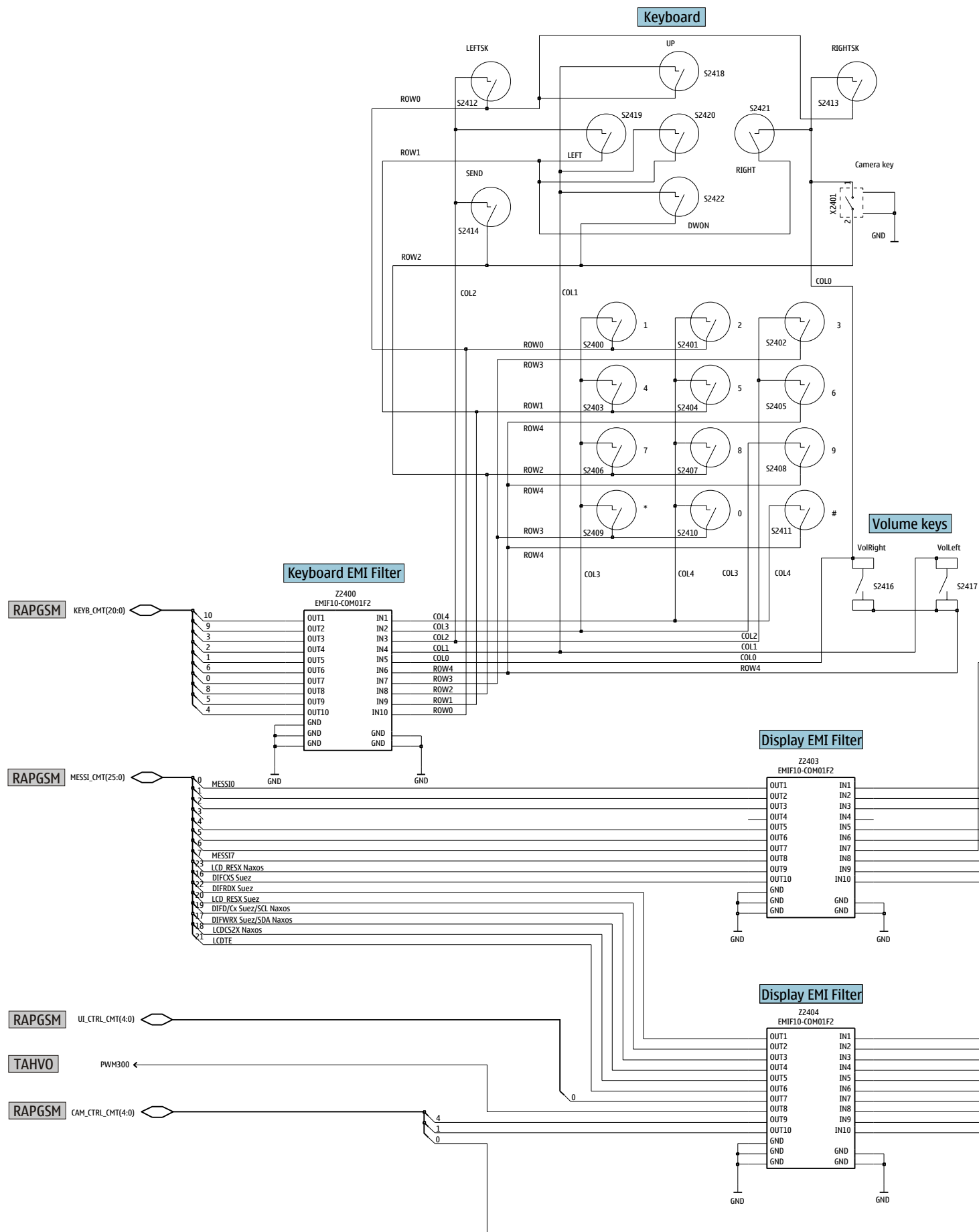

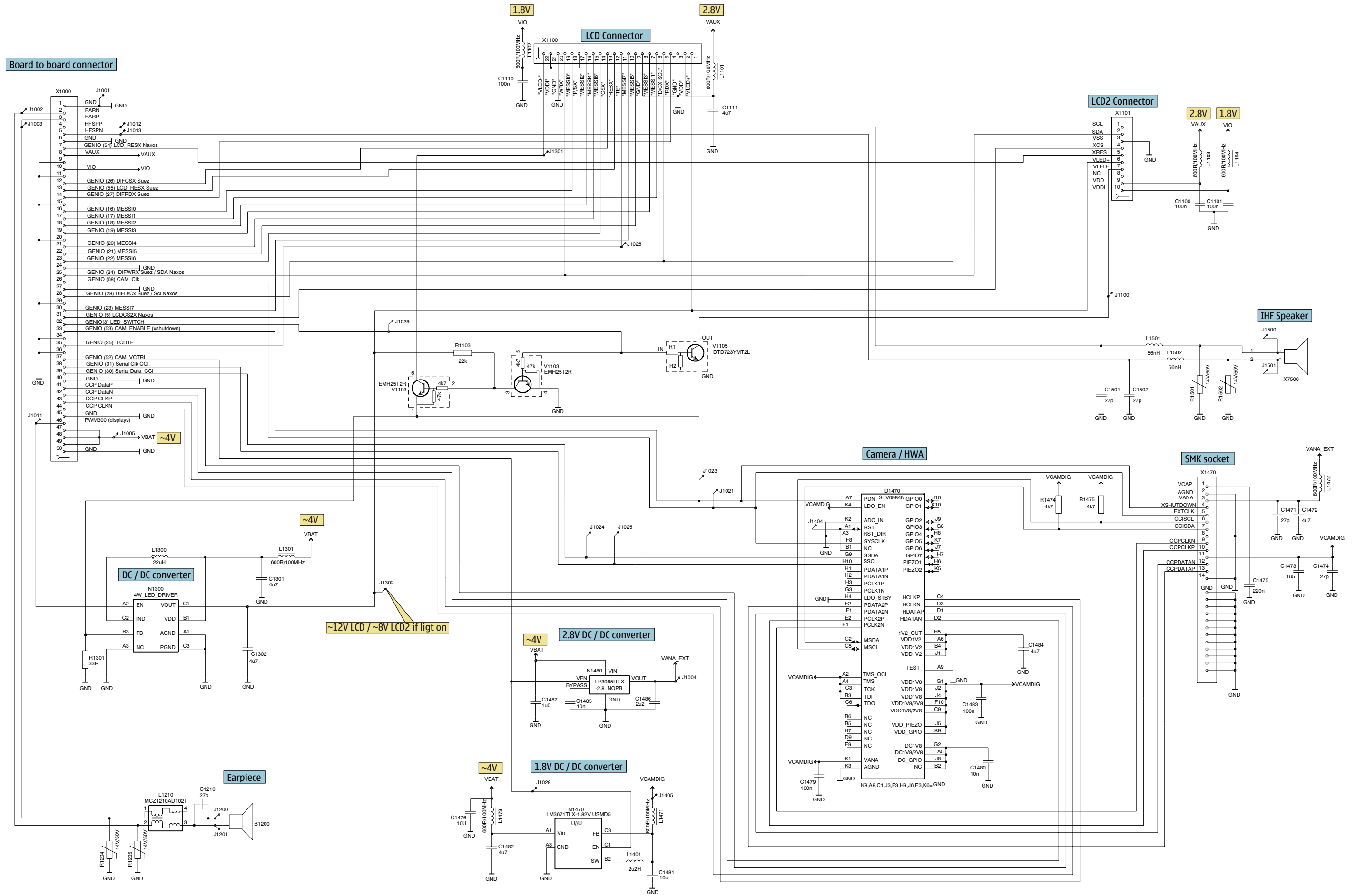

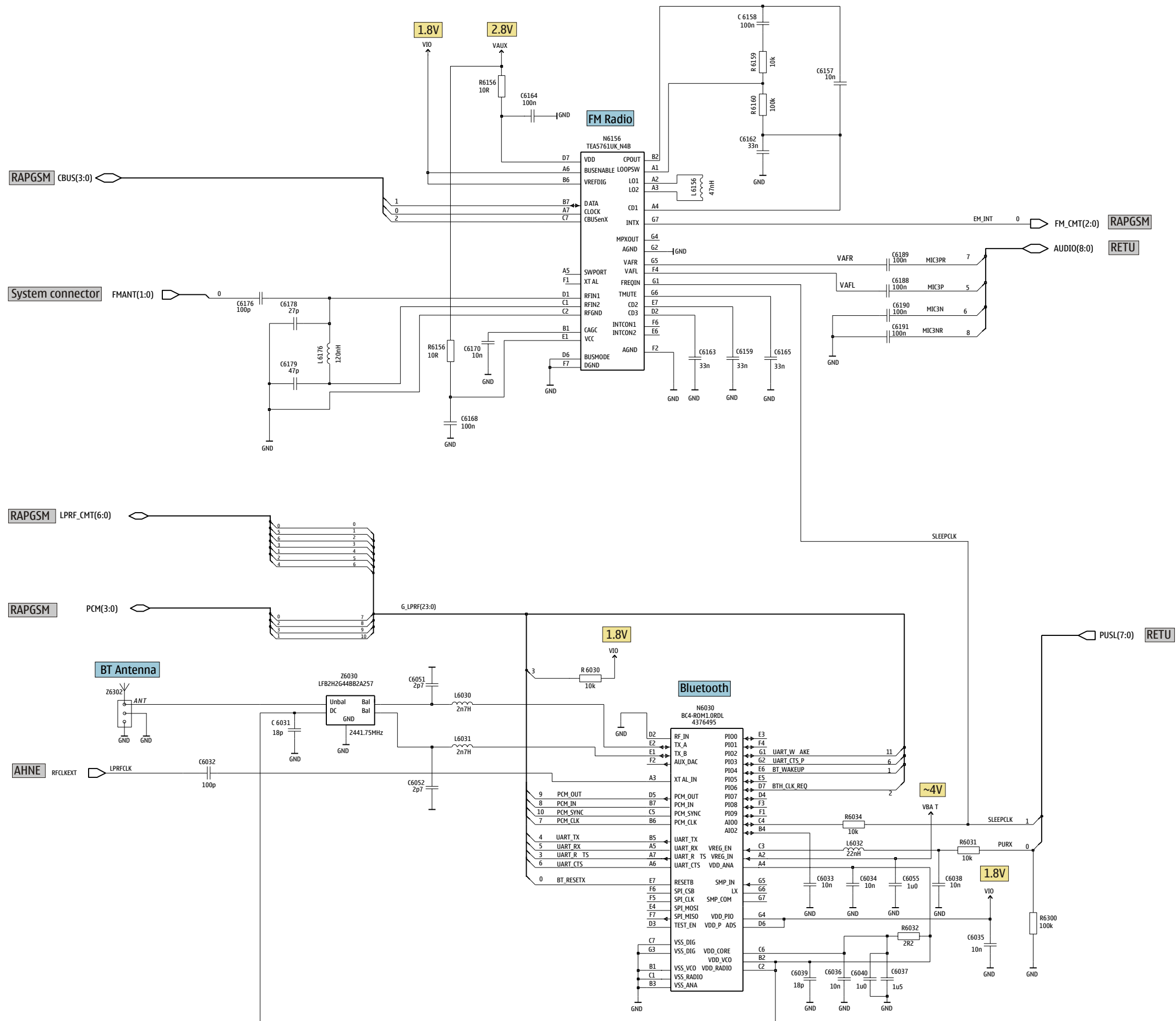

Band	Channel	RX	VCO/RX	VC/RX	TX	VCO/TX	VC/TX
GSM 850	190	881.6MHz	3526.4MHz	~1.8V	836.6MHz	3346.4MHz	~1.5V
GSM 900	37	942.4MHz	3769.6MHz	~2.73V	897.4MHz	3589.6MHz	~1.99V
GSM 1800	700	1842.8MHz	3685.6MHz	~2.39V	1747.8MHz	3495.6MHz	~1.60V
GSM 1900	661	1960.0MHz	3920.0MHz	~3.31V	1880.0MHz	3760.0MHz	~2.96V

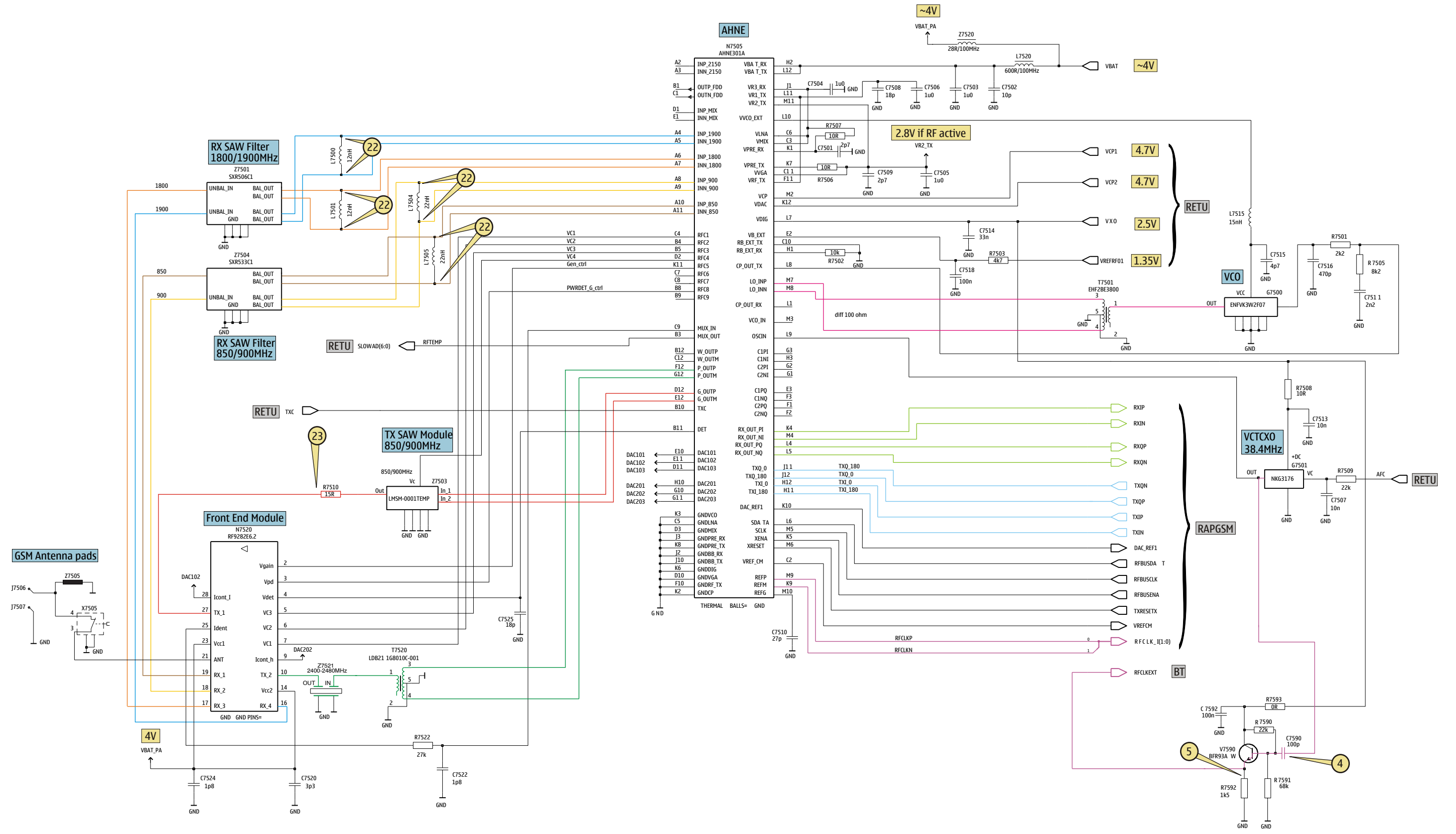

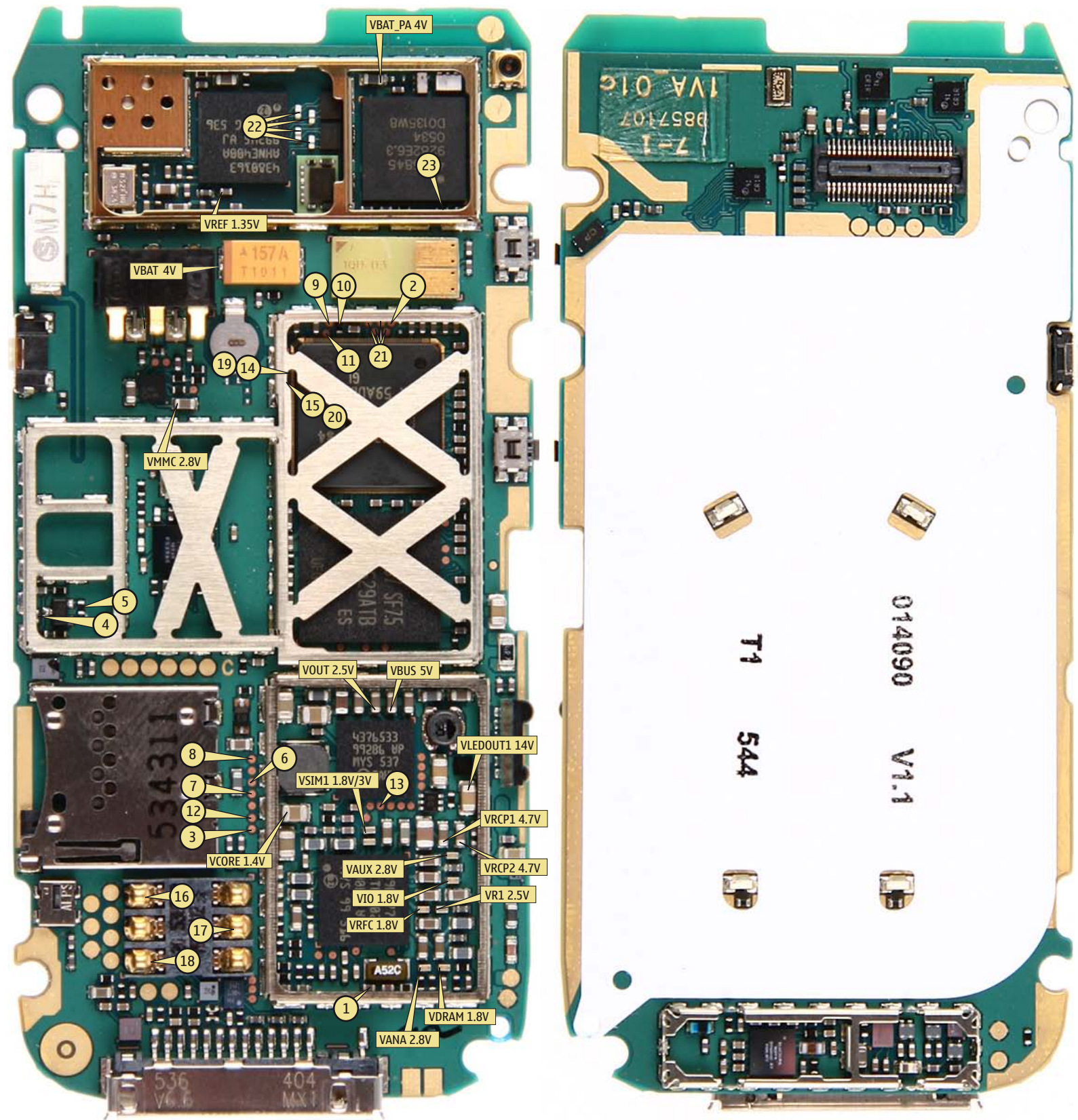
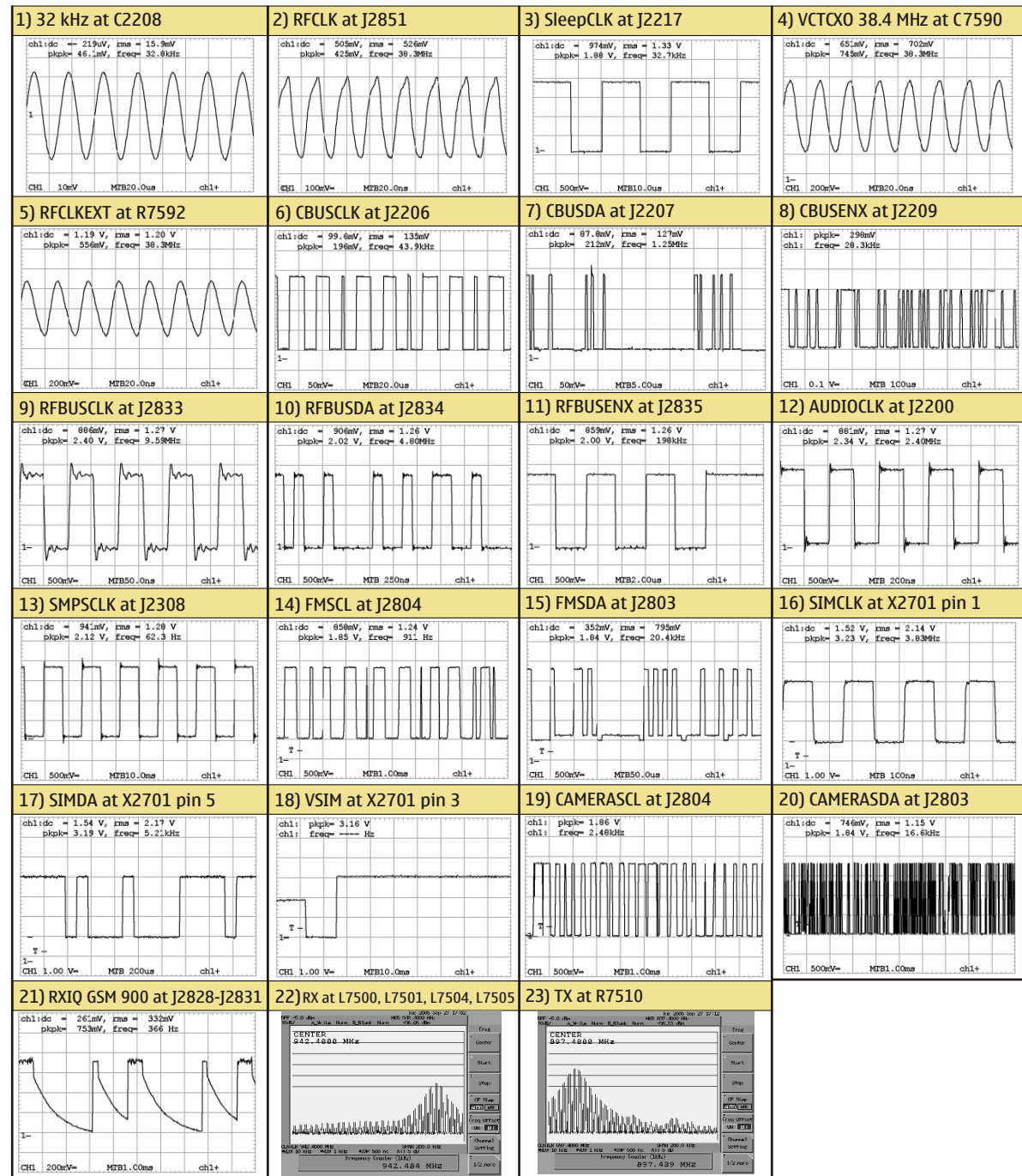

B	C2231	N5	C2815	F7	C6191	Q5	J2219	N4	L2404	D7	R2307	L4	V2000	O8	
B2100	Q1	C2232	O7	C2816	I5	C7501	C4	J2300	N6	L2405	C5	R2400	O4	V2302	L4
B2200	P6	C2270	O5	C2819	I5	C7502	D4	J2308	N6	L2406	D5	R2401	O4	V2400	O6
C	C2271	O5	C2820	F6	C7503	D3	J2309	M7	L2407	D5	R2402	D8	V2401	I6	
C2000	N8	C2272	O5	C2821	I7	C7504	B4	J2310	M7	L2408	D5	R2403	N6	V2402	I3
C2001	N8	C2273	N6	C2822	F5	C7505	D3	J2311	N6	L2409	D5	R2404	G1	V2403	O3
C2002	R4	C2274	N6	C2823	I6	C7506	D3	J2312	M7	L3200	L2	R2405	F5	V7590	K1
C2003	R4	C2275	N5	C2824	J5	C7507	D3	J2313	N7	L6030	I3	R2406	O6	X	
C2004	R4	C2281	O8	C2825	F7	C7508	D3	J2314	N7	L6031	I3	R2407	O3	X2000	R4
C2005	R3	C2300	M5	C2826	I8	C7509	D3	J2315	M7	L6032	J3	R2410	Q1	X2002	R7
C2006	R3	C2301	L5	C2828	I7	C7510	D4	J2803	G5	L6156	R5	R2600	K8	X2060	B5
C2007	Q2	C2302	N5	C2829	G8	C7511	C3	J2804	G5	L6176	Q6	R2700	Q4	X2070	F3
C2008	Q3	C2303	L7	C2830	H5	C7513	D3	J2828	F6	L7500	C5	R2701	D3	X2400	D4
C2009	Q3	C2304	N6	C2831	I7	C7515	B3	J2829	F6	L7501	C5	R2702	D3	X2401	G1
C2010	Q3	C2305	L8	C2832	G8	C7516	C3	J2830	F6	L7502	D4	R2803	I8	X2701	P3
C2011	R3	C2306	M4	C2833	I6	C7518	D4	J2831	F6	L7503	D7	R2804	H8	X3200	M2
C2012	R3	C2307	L6	C3000	K5	C7520	C7	J2833	F6	L7504	C5	R2806	F6	X7505	B8
C2013	R3	C2309	L5	C3001	J5	C7522	D6	J2834	F6	L7505	C5	R3000	J5	Z	
C2014	R3	C2310	L6	C3002	K5	C7523	B7	J2851	F7	L7515	C3	R3002	H8	Z2000	Q5
C2015	Q4	C2312	L6	C3003	I8	C7524	D6	J3000	K6	N		R3003	I8	Z2001	Q4
C2071	G3	C2313	L7	C3004	J8	C7525	D8	J3001	K6	N2300	M6	R3004	K7	Z2003	Q5
C2072	P2	C2314	M7	C3005	J8	C7590	K1	J3002	I5	N2301	M8	R3200	L1	Z2400	D6
C2073	E5	C2315	N8	C3006	K8	C7592	J1	J3003	K6	N2302	N7	R3201	G4	Z2403	B4
C2074	E2	C2316	N8	C3007	K8	D		J3004	J7	N2401	E8	R3202	G3	Z2404	C3
C2100	Q2	C2317	N8	C3008	J8	D2200	O6	J3005	J7	N2600	M8	R3203	K5	Z6030	I3
C2101	Q2	C2400	N4	C3009	K8	D2800	H6	J3006	I7	N3200	G3	R3204	L4	Z6302	E1
C2102	Q2	C2401	N4	C3200	L2	D3000	J6	J3112	L4	N6030	J3	R3205	G3	Z7501	C6
C2103	E8	C2402	D8	C3201	G2	F		J3113	L3	N6156	R5	R3206	G4	Z7503	D5
C2104	E8	C2403	C4	C3202	G3	F2000	P8	J3114	L3	N7505	C4	R6030	J4	Z7504	C6
C2200	O5	C2404	C5	C3203	H3	F2400	D5	J3115	L3	N7520	D7	R6031	I3	Z7520	B6
C2201	P7	C2406	C4	C3204	L4	G		J3116	L2	R		R6032	J3	Z7521	C7
C2202	P8	C2407	C4	C3205	G3	G2200	G4	J3117	L2	R2000	Q4	R6034	I4		
C2203	P6	C2408	C5	C6031	I3	G7500	C3	J3200	G3	R2001	Q4	R6156	R5		
C2204	P6	C2410	D4	C6032	J4	G7501	D2	J3201	G3	R2002	Q3	R6157	Q6		
C2205	P5	C2411	D3	C6033	J4	J		J3203	G3	R2003	Q3	R6159	Q5		
C2206	P6	C2412	N6	C6034	J4	J2000	P8	J7506	B8	R2004	Q2	R6160	Q5		
C2207	P7	C2413	D8	C6035	J3	J2001	O8	J7507	C8	R2005	Q3	R6300	I3		
C2208	Q6	C2414	F4	C6036	J3	J2002	P6	L		R2006	Q3	R7501	C3		
C2209	Q6	C2415	C3	C6037	J3	J2003	Q3	L2000	O8	R2007	Q4	R7502	B4		
C2210	N7	C2416	C4	C6038	I3	J2004	Q3	L2001	Q3	R2008	Q4	R7503	D4		
C2211	N7	C2417	D5	C6039	I4	J2005	R2	L2002	Q3	R2009	Q4	R7505	C3		
C2212	N6	C2600	K8	C6040	J3	J2006	Q2	L2003	R3	R2070	P2	R7506	D3		
C2213	O7	C2601	L8	C6051	I3	J2007	Q4	L2004	R3	R2071	G3	R7507	B4		
C2214	O7	C2602	L8	C6052	I3	J2008	Q4	L2202	P8	R2100	Q2	R7508	D3		
C2215	O7	C2700	Q3	C6055	J4	J2009	P4	L2203	O8	R2101	P2	R7509	D3		
C2216	O7	C2800	H8	C6157	Q4	J2060	P2	L2204	P8	R2200	P8	R7510	D7		
C2217	P7	C2801	F7	C6158	Q4	J2070	E3	L2205	P8	R2201	P7	R7522	D7		
C2218	P6	C2802	H8	C6159	R6	J2071	E4	L2206	O7	R2202	P5	R7523	C7		
C2219	P7	C2803	H8	C6162	R4	J2072	E4	L2211	N5	R2203	P5	R7590	K1		
C2220	N6	C2804	F7	C6163	R6	J2200	N4	L2212	N6	R2204	P5	R7591	K1		
C2221	N8	C2805	F7	C6164	R5	J2204	P5	L2270	O5	R2205	P5	R7592	K2		
C2222	N7	C2806	F8	C6165	R6	J2205	P6	L2271	O5	R2206	P5	R7593	J1		
C2223	O5	C2807	I5	C6168	Q6	J2206	M4	L2301	L5	R2207	P5	S			
C2224	P5	C2808	G8	C6170	Q5	J2207	N4	L2302	M5	R2208	P5	S2416	E8		
C2225	P7	C2809	G8	C6176	R6	J2209	M4	L2304	M7	R2209	P5	S2417	H8		
C2226	O7	C2810	I8	C6178	Q6	J2210	P6	L2305	L7	R2212	O5	S3200	O1		
C2227	N6	C2811	F5	C6179	Q5	J2212	J8	L2306	M4	R2213	P7	T			
C2228	O7	C2812	H8	C6188	Q6	J2216	N6	L2401	C3	R2214	P8	T7501	C2		
C2229	N6	C2813	F5	C6189	R6	J2217	N4	L2402	C4	R2216	Q7	T7520	C7		
C2230	P7	C2814	G8	C6190	Q5	J2218	M4	L2403	C5	R2301	N7	V			

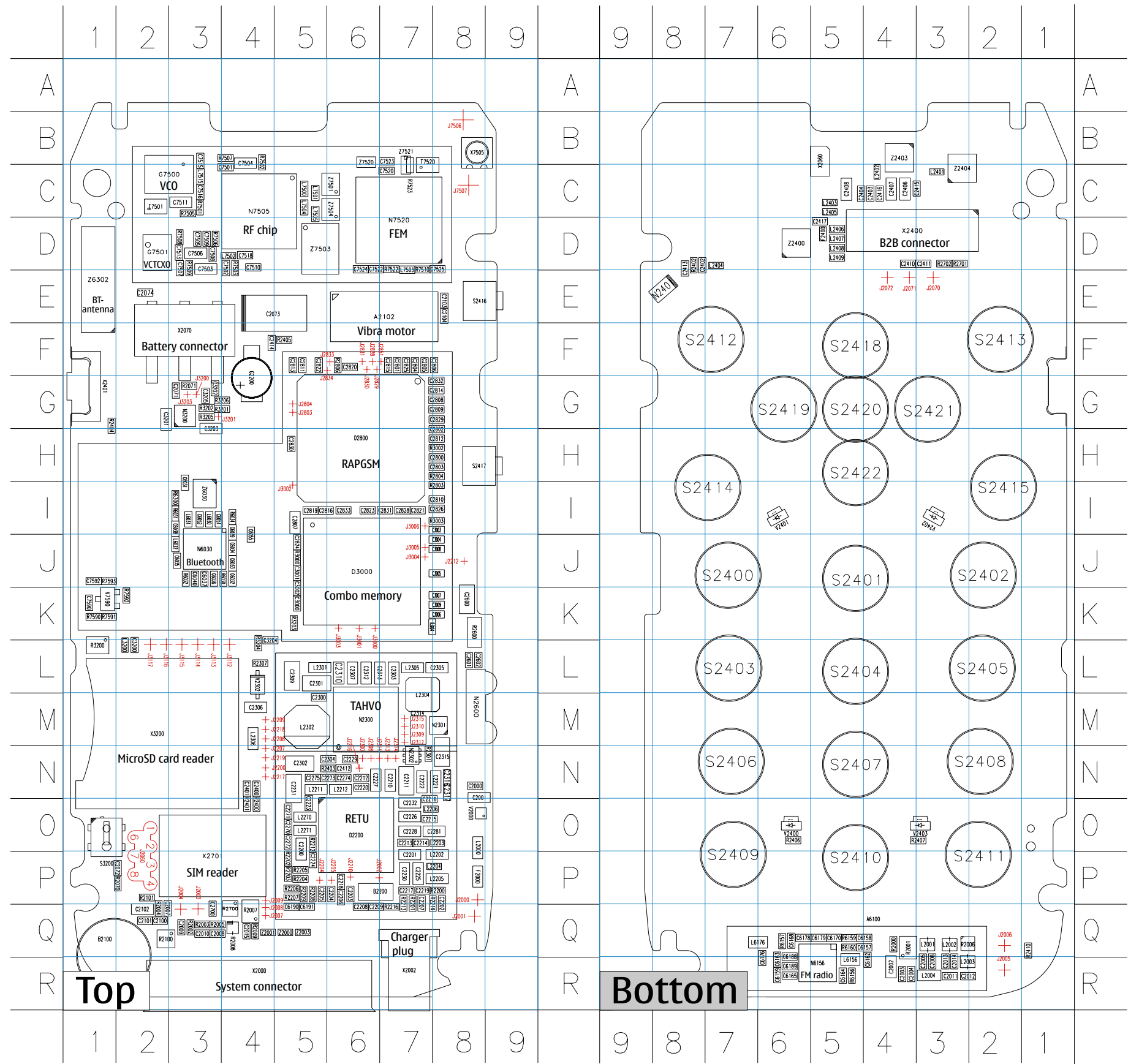

B	J1026	B7	
B1200	O4	J1028	C7
C	J1029	E4	
C1100	L6	J1100	F2
C1101	L7	J1200	O6
C1102	N7	J1201	O7
C1103	N6	J1301	F2
C1104	N6	J1302	F3
C1105	N6	J1404	E3
C1110	O7	J1405	E5
C1111	O7	J1500	K4
C1112	O7	J1501	K3
C1113	N7	L	
C1114	N7	L1101	O8
C1210	O6	L1102	O8
C1301	C3	L1103	L6
C1302	C2	L1104	L7
C1471	B6	L1210	O6
C1472	A7	L1300	C2
C1473	D6	L1301	C3
C1474	D6	L1401	C7
C1475	B6	L1471	D7
C1476	C8	L1472	B7
C1479	B3	L1473	C8
C1480	D3	L1501	O4
C1481	D7	L1502	N3
C1482	C8	N	
C1483	C3	N1300	C2
C1484	C3	N1470	C7
C1485	C7	N1480	B7
C1486	B7	R	
C1487	B7	R1103	C2
C1501	O3	R1204	O6
C1502	N2	R1205	O6
D	R1301	C1	
D1470	C2	R1474	B2
J	R1475	B2	
J1001	D6	R1501	O4
J1002	D9	R1502	O3
J1003	D8	V	
J1004	B9	V1103	D2
J1005	C9	V1105	D2
J1011	B8	X	
J1012	F8	X1000	C8
J1013	F8	X1100	O6
J1021	B4	X1101	M7
J1023	C7	X1470	C5
J1024	E2	X7506	M4
J1025	E2		

